

User Guide



Gasurveyor 700

Part Number: 49391
Issue: 1
Release Date: 10.06.16

Notification Icons



Warning: Information to help prevent injury or damage



Note: Notes, tips or additional information

Copyright

© 2016 Gas Measurement Instruments Ltd.

This user guide is copyright of Gas Measurement Instruments Ltd (GMI) and the information contained within is for use only with Gasurveyor 700 instruments. Reproduction, in whole or part, without written permission of GMI is prohibited.

Essential Health & Safety Requirements



General

- Read and understand this user guide before operating.
- The instrument must be regularly serviced and calibrated by fully trained personnel in a safe area.
- Only GMI replacement parts should be used.
- Substitution of components may impair intrinsic safety.
- If the instrument detects gas, follow your own organisation's procedures and operational guidelines.
- This equipment is designed and manufactured to protect against other hazards as defined in paragraph 1.2.7 of Annex II of the ATEX Directive 94/9/EC until 19th April 2016, and ATEX directive 2014/34/EU from the 20th April 2016.

Battery / Charging

- Alkaline and rechargeable batteries must be exchanged in a safe area and fitted correctly before use.
- Never use damaged batteries or expose to extreme heat.
- Rechargeable batteries must be recharged in a safe area, using the GS700 Charging Cradle.
- Only use approved alkaline batteries.
- Do not mix old and new batteries.

Areas Of Use

- Do not use instrument in potentially hazardous atmospheres containing greater than 21% Oxygen.
- Exposure to certain chemicals can result in a loss of sensor sensitivity. Where such environments are known or suspected it is recommended that more frequent response checks are carried out. Chemical compounds that can cause loss of sensitivity includes Silicones, Lead, Halogens and Sulphur.

Storage, Handling And Transit

- Batteries should be removed if the instrument is stored for longer than 3 months.
- The instrument can contain electrochemical sensors. Under conditions of prolonged storage these sensors should be removed. The sensor contains potentially corrosive liquid and care should be taken when handling or disposing of the sensor, particularly when a leak is suspected.
- The instrument is designed to handle harsh environments and is IP55 rated. If not subject to misuse or malicious damage, the instrument will provide many years of reliable service.

Special Conditions Of Use

- Only use permitted external probes specified by certificate number.
- The equipment must not be subject to prolonged exposure to light when not in use.

Any right of claim relating to product liability or consequential damage to any third party against GMI is removed if the warnings are not observed.

Equipment Parameters

GS700 Instrument:

U_m : 6.78V (Rechargeable Battery, part number - 49221)

Temperature Range: $-20^{\circ}\text{C} \leq T_a \leq 50^{\circ}\text{C}$

GS700 Charger:



U_m : 250V

U_o : 6.78V

Temperature Range: $-20^{\circ}\text{C} \leq T_a \leq 44^{\circ}\text{C}$

Certification

Gasurveyor 700 instruments are certified as:

ATEX		II 2 G Ex db ia IIC T4 Gb $-20^{\circ}\text{C} \leq T_a \leq 50^{\circ}\text{C}$ * II 2 G Ex db ia IIB T3 Gb $-20^{\circ}\text{C} \leq T_a \leq 50^{\circ}\text{C}$ SIRA 15 ATEX2299X
IECEX		Ex db ia IIC T4 Gb $-20^{\circ}\text{C} \leq T_a \leq 50^{\circ}\text{C}$ * Ex db ia IIB T3 Gb $-20^{\circ}\text{C} \leq T_a \leq 50^{\circ}\text{C}$ IECEX SIR 15.0105X
CSA		Class I, Div.1 Groups A, B, C and D T4 Class I, Zone 1 AEx db ia IIC T4 Gb Ex db ia IIC T4 Gb *Class I, Div.1 Groups C and D T3 *Class I, Zone 1 AEx db ia IIB T3 Gb Ex db ia IIB T3 Gb

* The GS7xx series is certified for use with for Gas Group IIC, Temperature Classification T4 except when the PPM gas sensor is fitted. With a PPM gas sensor fitted either internally or externally the GS7xx is certified for Gas Group IIB and Temperature Classification T3.

Additional Safety Details - CSA Only

CAUTION: Before each days Usage, test on a known concentration of methane, equivalent to 25 - 50% of full scale concentration. Accuracy must be within 0 to +20% of actual. Accuracy may be corrected by calibration. (Refer to Chapter: 'CALIBRATION').

ATTENTION: Avant chaque utilisation journalière, testez la réaction de l'appareil en utilisant une concentration connue en méthane, correspondant à 25-50% de la lecture à fond d'échelle. La précision doit se situer entre 0 et +20% de la valeur réelle. La précision peut se corriger en étalonnant l'appareil (voir Chapitre: CALIBRATION).

CAUTION: Any rapid up-scale readings followed by a declining or erratic reading may indicate a gas concentration beyond the upper scale limit, which may be hazardous.

ATTENTION: Toute lecture dépassant rapidement le maximum de l'échelle et suivie par une diminution ou une lecture erronée, indique une concentration de gaz supérieure à la valeur maximale de cette échelle. Cette lecture n'est pas significative.

CAUTION: Substitution of components may impair intrinsic safety.

ATTENTION: le remplacement d'un composant peut porter atteinte à la sécurité intrinsèque du produit.

CAUTION: Do not charge in a hazardous area. Um = 6.78V.

ATTENTION: Ne pas charger en zone dangereuse. Um = 6.78V.

NOTE: CSA have only assessed the LEL combustible gas detection portion of this instrument for performance.

NOTE: CSA a seulement évalué la partie LIE pour la mesure des performances en détection de gaz inflammables.

CAUTION: Electromagnetic interference (EMI) signals may cause the instrument operation to become erroneous.

NOTE: The instrument contains internal checking of sensor sensitivity, which during calibration will prevent the sensor being calibrated if it has been contaminated or reached its end of life. In addition to this the Instrument Management System (IMS) can be used to track the condition of sensors from stored calibration results.

Contents

Notification Icons	2
Copyright	2
Essential Health & Safety Requirements	3
General	3
Battery / Charging	3
Areas Of Use	3
Storage, Handling And Transit	3
Special Conditions Of Use.....	3
Equipment Parameters	4
Certification	4
Additional Safety Details - CSA Only	5
Getting Started	9
Overview	9
Key Features	9
Display	10
Soft-Keys.....	10
Status Bar	11
Gas Ranges	11
Battery Packs	12
Operation	13
Switch On	13
Warm-up Sequence	13
Switch Off.....	14
Soundness Test (Optional)	15

Modes of Operation.....	16
Gas Leak Outdoors (GLO)	17
Additional Functions	17
Pipeline Gas Test (PGT).....	18
Purge	19
Search.....	19
Barhole Testing	20
Confined Space Monitoring (CSM)	22
Alarms	24
Alarm Acknowledge.....	24
Gas Alarm Types	25
Alarm Mute.....	27
Confidence Signal	27
Fault Alarm Types.....	28
Battery / Charging.....	30
Replacing Alkaline Batteries.....	30
Recharging the Battery Pack.....	32
Replacing the Battery Pack.....	35
Maintenance.....	36
Cleaning.....	36
Probe Handle Filter Replacement.....	36
Replacing the Dust Filter	37
Bump Test (Optional)	38
Automatic Bump Test	38
Manual Bump Test.....	38
Calibration	41
Automatic Calibration	41
Manual Calibration	41
Calibration Validity.....	41

Accessories / Spares	42
Accessories	42
Common Spares.....	43
Specification	44
Instrument Performance.....	44
Instrument Specification.....	45
Alarm Set-points	46
Soft-Key Button Glossary.....	47
Warranty	48
Liability	48
Customer Support	48
Disposal	48
Contact Details	49

Getting Started

Overview

The Gasurveyor 700 (GS700) is the first choice for all gas utility applications.

Reliable measurements are performed using innovative infrared sensing technology including instantaneous confirmation that the gas sample is natural gas.

This lightweight, rugged instrument is easy to use thanks to an intuitive menu layout on a large display.



Key Features

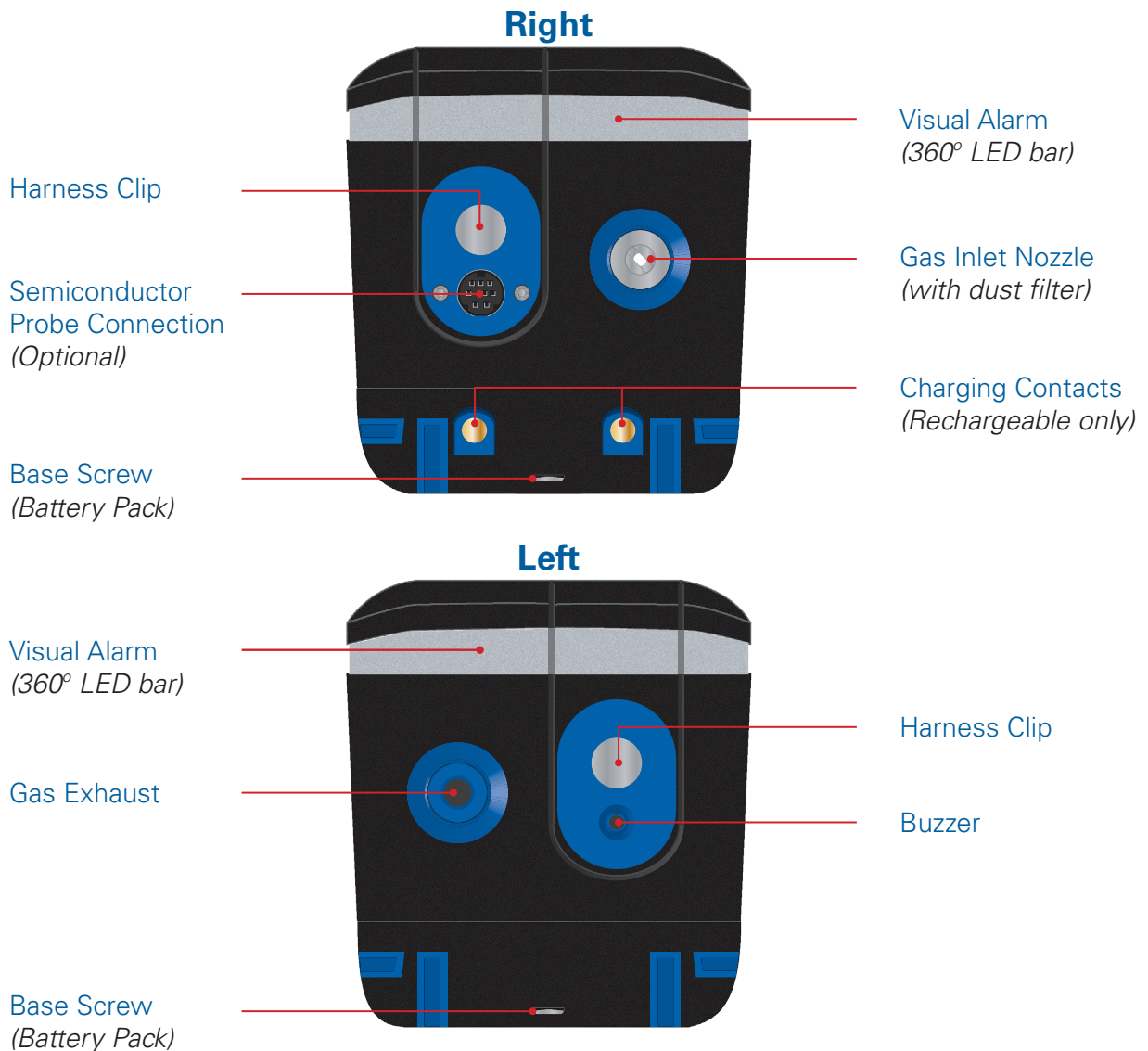

Top

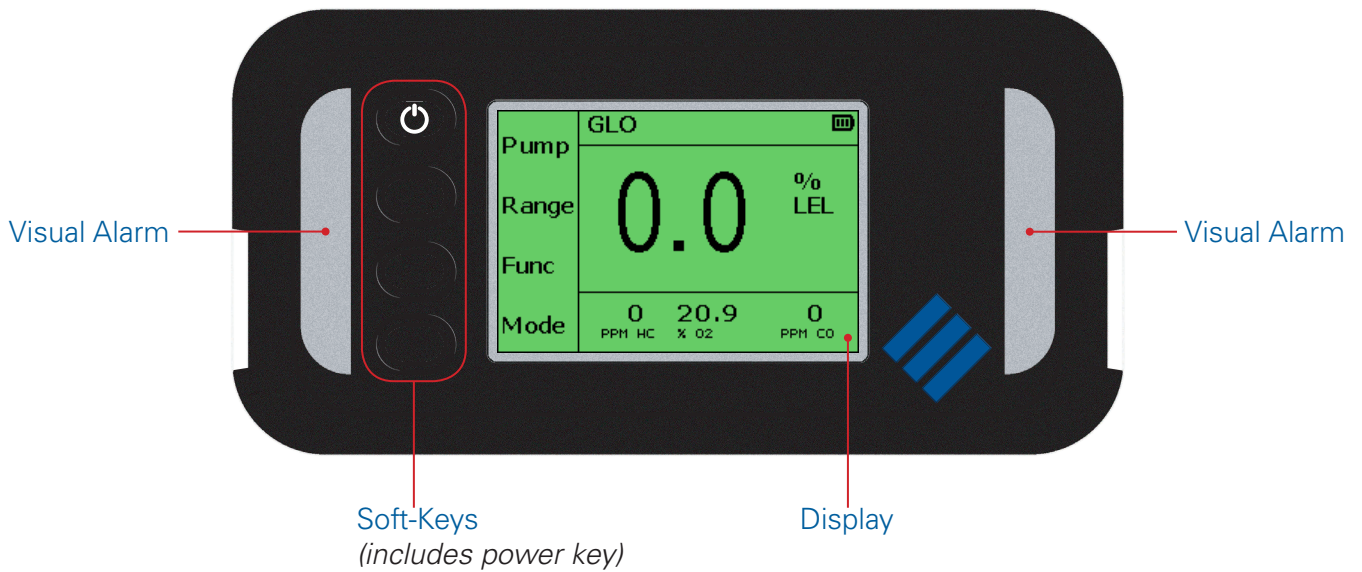

Display

The GS700 is a fully configurable instrument, the menu structure and information displayed may vary.

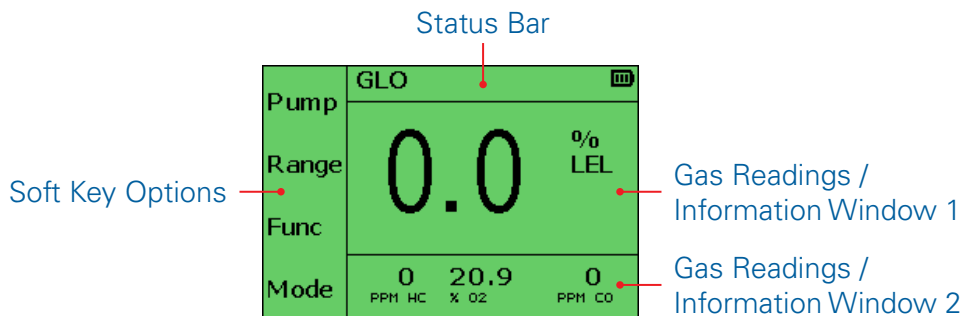

i The above display will be used throughout this user guide as the example main display.

Soft-Keys

The GS700 has 4 soft-keys performing different operations depending on mode and function.

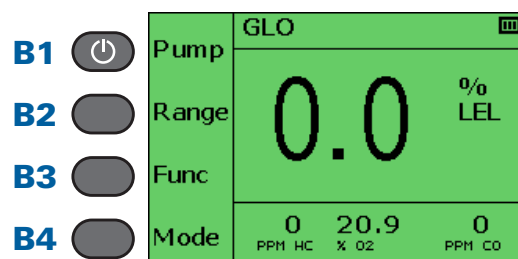

The soft-keys shall be referred to as **B1**, **B2**, **B3**, and **B4** throughout this user guide.

i **B1** also acts as power on / off.







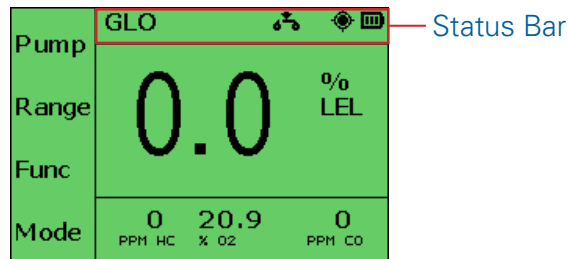

i For soft-key menu options, see *“Soft-Key Button Glossary”*.

Status Bar

Displays current operating mode. Icons provide information about instrument status.



Status bar icons:

Icon	Description
	Battery Indicates the current battery level.
	Datalogging Indicates a manual or automatic datalog is being undertaken.
	Geiger - audible & visual alarms off Indicates the audible and visual alarms are switched off when using the Geiger feature.
	Geiger - audible alarm on Indicates the audible alarm is present when using the Geiger feature.
	Geiger - visual alarm on Indicates visual alarms are present when using the Geiger feature.
	Geiger - audible & visual alarm on Indicates the audible and visual alarms are present when using the Geiger feature.
	GPS Indicates the location of the instrument has been found. If flashing the instrument is acquiring a GPS location.
	Pump Indicates the pump is operating at high speed.

Gas Ranges

The GS700 can detect the following:

- Infrared measurement of flammable gases (LEL & volume) - e.g. Methane, Butane
- ppm flammable gas via sensor or external semiconductor probe
- Oxygen
- Toxic gases - e.g. Carbon Monoxide, Hydrogen Sulphide
- Differentiation between Pipeline Gas (natural gas) and Non Pipeline Gas (e.g. Landfill or swamp gas)



For more details, [see "Instrument Performance"](#).

Battery Packs

The GS700 has 2 battery options:

- Alkaline.
- Lithium-Ion rechargeable, fully charge before first use.



Only use GMI approved batteries and chargers. Batteries must be charged (or replaced) in a safe area.



For further information, [see "Battery / Charging"](#).

Battery Level

- Battery level is displayed during GS700 warm-up.

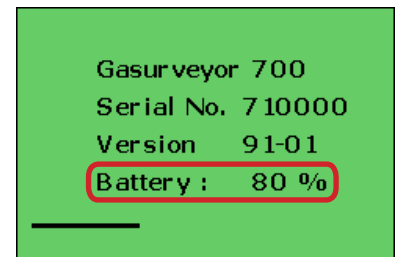

- During operation, the battery icon shows the battery level.

Icon Status	Battery Level
	0% - 24%
	25% - 49%
	50% - 74%
	75% - 100%

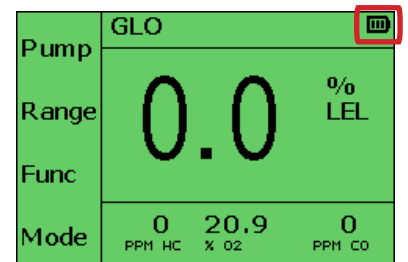

Battery Run Time

Battery Type	Run Time *
Alkaline	20 hours
Rechargeable	20 hours

* approximate



Times based on normal operation at ambient temperatures.

Operation

Switch On

- Press and hold **B1** for 1 second.
- The instrument will go through a warm-up sequence.



Always switch the instrument on in fresh air.

Warm-up Sequence



Typical warm-up sequence.

1. GMI logo and instrument type.
Progress Bar increases during warm-up (~60s).



2. Instrument:
 - Type
 - Serial number
 - Software version
 - Battery level

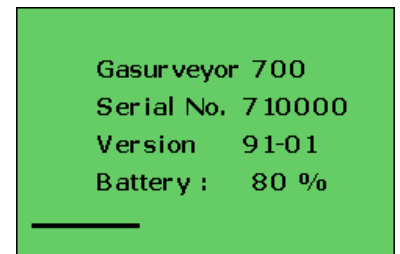

3. Date and time.

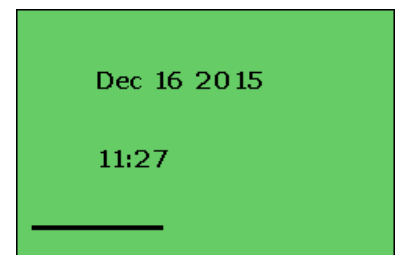

4. Sensor zero check.

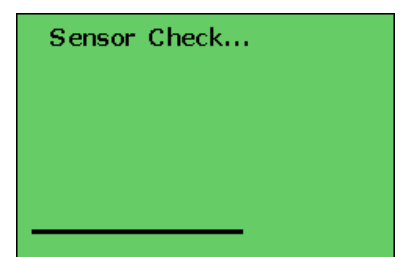

5. Sensors are zeroed correctly.

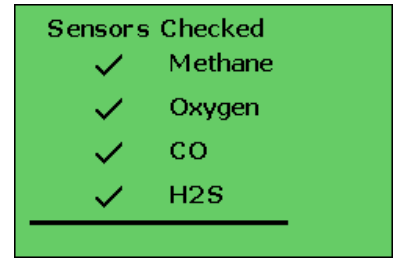

6. Typical operating display.

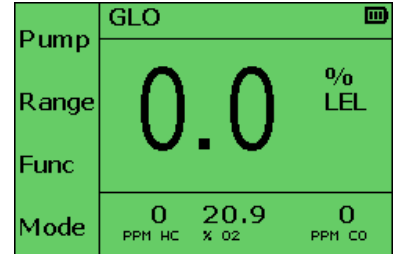

Switch Off

- Press and hold **B1** for 3 seconds.

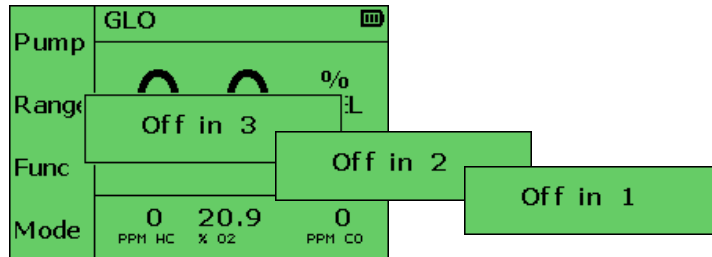

To abort switch off, release **B1**.



The next time the GS700 is switched on, the display will show the operating mode used prior to switch off.

Soundness Test (Optional)

A soundness test verifies the instrument and probe are not leaking.

- A soundness test is performed during instrument warm-up.
- Block the gas inlet (sample path).
- The test will last for 5 seconds.

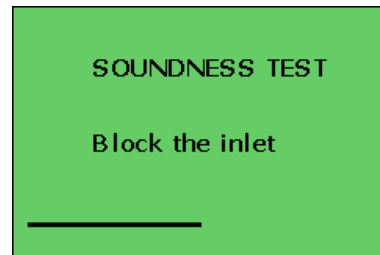

- If the instrument and probe are not leaking the soundness test will pass.
- Unblock the gas inlet (sample path) to continue.

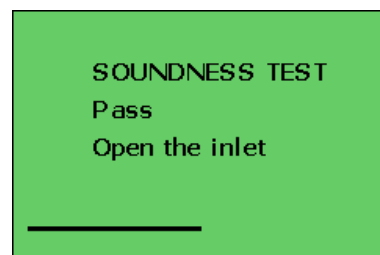

- If a leak is detected, in the instrument or probe, the soundness test will fail.
- Once the leak has been rectified, press **B4** to retry.

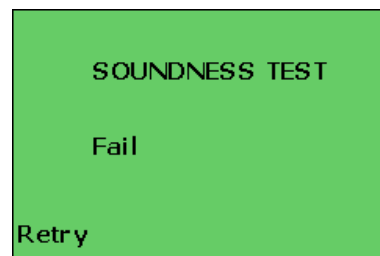

The GS700 cannot be used until the soundness test has passed.

Modes of Operation

The user can configure the GS700 to have up to 4 modes of operation, including:

- Gas Leak Outdoors (GLO)
- Pipeline Gas Test (PGT)
- Purge
- Search
- Confined Space Monitor (CSM)

- Pressing **B4** will display the configured modes of operation.

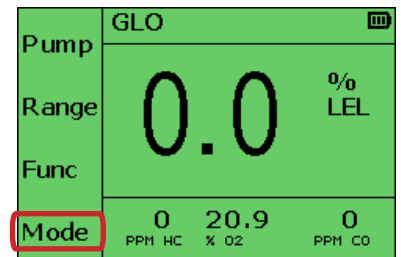

Mode selection will be displayed for 5 seconds.

- To enter 'Pipeline Gas Test' mode, press **B2**.

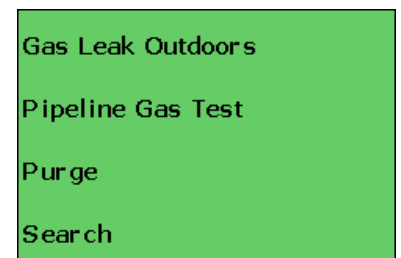

Selected mode is displayed in the status bar.

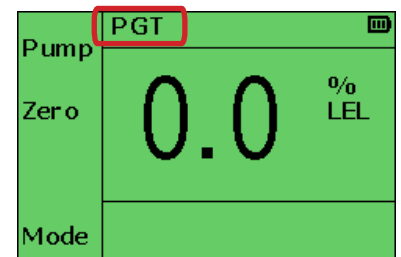

Gas Leak Outdoors (GLO)

In this mode, the GS700 acts as a gas indicator drawing a gas sample, via a probe, where gas is suspected to be present. Alarms are disabled.

Typical features:

- Pump control
- Ability to measure various gas ranges
- Barhole testing
- Manual datalogging
- Sensor zeroing

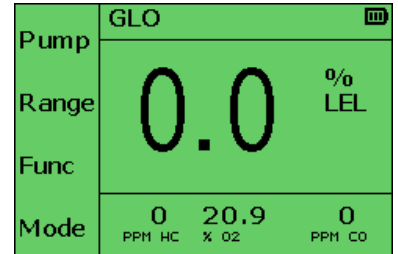

Pump Control

The pump must be ON to draw a gas sample. By default the pump is switched ON.

- Press **B1** to toggle the pump OFF / ON



Functionality is disabled when the pump is OFF.

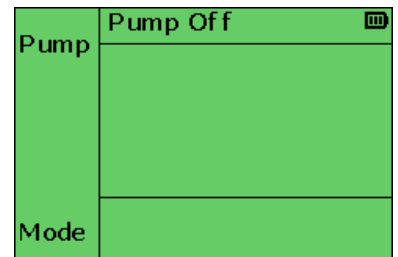

Additional Functions

- Pressing **B3** 'Func' displays additional features.

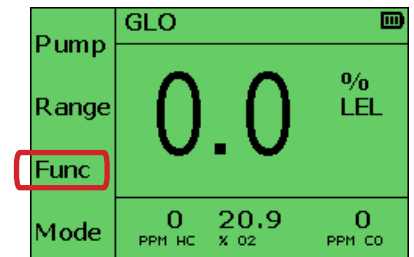

E.G.:

- Press **B1** - Barhole testing (B/H)
- Press **B2** - sensor zeroing (Zero)



Additional functions selection may also be displayed by a ↓ soft key.

Pipeline Gas Test (PGT)

In this mode, the GS700 is used to discriminate between pipeline gas (natural gas) and non pipeline gas (e.g. landfill or swamp gas).

Typical features:

- Discrimination between gases
- Pump Control
- Sensor Zeroing

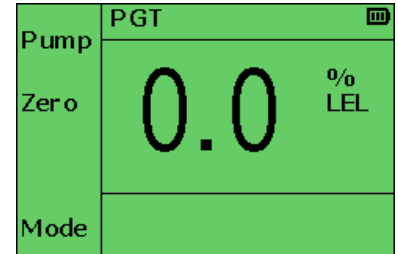

When sample testing, the GS700 discriminates the gas and displays the results, as follows:

Pipeline Gas

- Pipeline gas identified
- Peak gas reading displayed
- Green visual 360 LED's activated

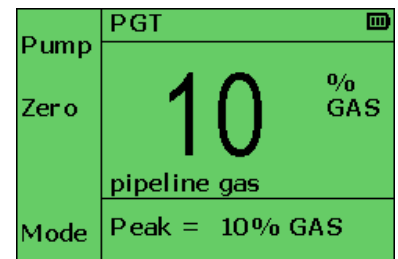

Non Pipeline Gas

- Non Pipeline gas identified
- Peak gas reading displayed
- Red visual top plate LED's activated

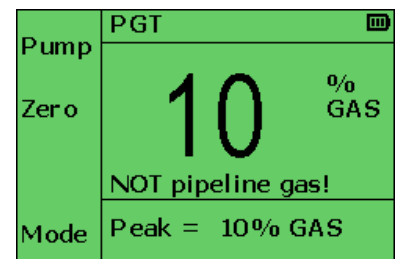

The live result of the Pipeline gas test will be displayed until the gas reading drops below the decision point (approximately 20% LEL). The option to clear the result is now presented.

- Press **B3** to clear result and peak gas reading.
- The following test information is logged when each result is cleared:
 - » Decision
 - » Peak reading
 - » Time and date
 - » GPS location
 - » User ID

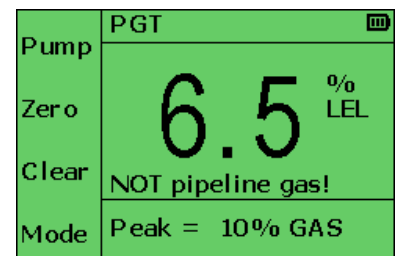



PGT can be configured to be an additional feature running in the background. In this configuration, from any mode, detection of Non Pipeline Gas will be displayed.

Purge

In this mode, the GS700 aids in the purging of pipework installations. Alarms are disabled.

Typical features:

- Pump Control
- Measuring ranges - volume gas or oxygen
- Sensor Zeroing

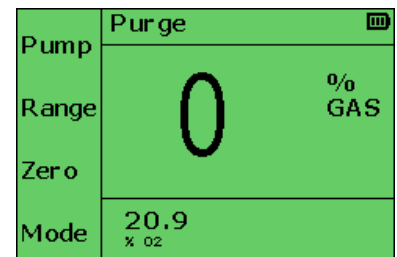

Search

In this mode, the GS700 is used for rapid leak detection.

Typical features:

- Measures 0 -10,000 PPM HC
- Pump Control
- Sensor Zeroing
- Audible and visual Geiger alarm (A/V), see “Geiger Alarm”.

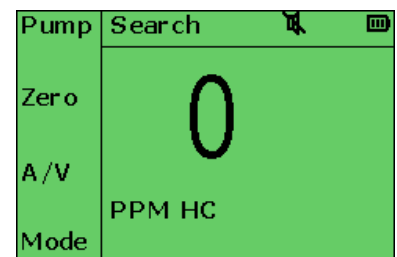

Pump Control

By default the pump is switched ON at normal speed.

- Press **B1** to toggle the pump between normal speed / high speed / OFF.
- A pump icon rotates to indicate high speed pump operation.

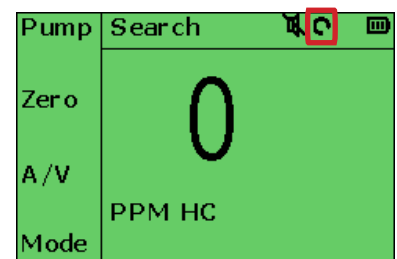

Barhole Testing

Barhole testing is normally contained within a mode, e.g. GLO mode.

Barholes are small holes placed, in the ground, along the route of an underground gas pipe. Gas leak detection is performed by placing a probe into the barhole.

The GS700 stores the following measurements when barhole testing:

- LEL /Volume Gas readings - peak and sustained
- Time and date
- GPS location

 Alarms and pump control are disabled during a barhole test.

To perform barhole testing:

1. Ensure the instrument is set to GLO mode.
2. Press **B3** for additional functions.

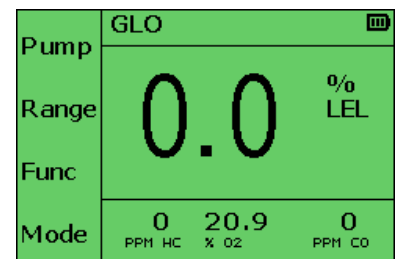

3. Press **B1** to select barhole testing (B/H).

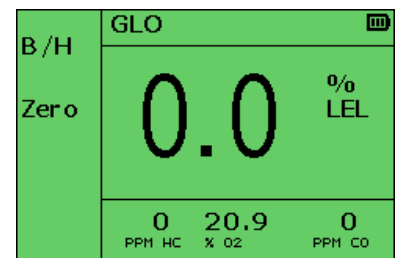

4. Press **B1** to start a new barhole series.
Press **B4** to continue with a previous series.

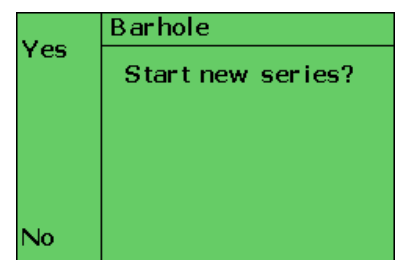

5. Press **B1** to start at 'Barhole number 01'.
To display different barhole numbers, press button **B2** and **B3** to move through the barhole numbers.
Press **B4** to exit.

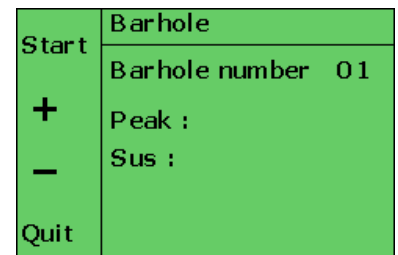

 Each series can store up to 25 barhole numbers.

GS700 USER GUIDE

6. The test can be aborted at any time by pressing **B1**.

Abort	Barhole C
	<div style="font-size: 2em; font-weight: bold;">0.0</div> <div style="text-align: right; font-size: 0.8em;">% LEL</div>
	Barhole number 01

7. The result of 'Barhole number 01' is displayed on completion. At this point, the instrument must be purged, press **B1**.

To view the results of other barhole tests, press **B2** and **B3** to move through the results.

Purge	Barhole
	Barhole number 01
+	Peak : 0.0% LEL
-	Sus : 0.0% LEL
	Jun 10 15:36

8. The next barhole number will be displayed.
Repeat steps 5 -7 to test 'Barhole number 02'.

Start	Barhole
	Barhole number 02
+	Peak :
-	Sus :
Quit	

9. If you wish to repeat (overwrite) a barhole test, e.g. at No. 1, press **B3** until 'Barhole number 01' is displayed.
Press **B1** to test 'Barhole number 01' again.

Start	Barhole
	Barhole number 01
+	Peak : 0.0% LEL
-	Sus : 0.0% LEL
	Jun 10 15:36
Quit	

10. Press **B1** to confirm and overwrite 'Barhole number 01'.
Press **B4** to reject and return to the previous display.

Yes	Barhole
	Barhole number 01
	Peak : 0.0% LEL
	Sus : 0.0% LEL
	Nov 19 11:49
No	Overwrite?

11. Press **B4** to exit barhole testing.

Start	Barhole
	Barhole number 06
+	Peak :
-	Sus :
Quit	

Confined Space Monitoring (CSM)

In this mode the GS700 acts as a safety monitor for use when entering confined spaces which may contain hazardous gas mixtures.

Typical features:

- Automatic datalogging (default - 60 seconds)
- View maximum / minimum / STEL / LTEL gas readings
- View alarm set-points
- Visual / Audible alarms
- Confidence Signal

	CSM	0 % LEL
View	20.9	% O2
Mode	0	PPM H2S
		0 PPM CO

 The pump is always ON in CSM mode.

 A zero fault cannot be zeroed in CSM mode. Change mode to zero. Always zero in fresh air.

View Gas Readings / Alarm Set-points

1. By pressing **B3**, the menu sequence to view measured gas readings and alarm set-points are displayed.

 The display will return to the CSM normal display, after 5 seconds.

	CSM	0 % LEL
View	20.9	% O2
Mode	0	PPM H2S
		0 PPM CO

2. Maximum readings.
 Press **B1** to continue.
 Press **B3** to return to the CSM normal display (Live).
 Press **B4** to reset the readings.

	Max	24 % LEL
Next	20.9	% O2
Live	8	PPM H2S
Clr	286	PPM CO

3. Minimum readings.
 Press **B1** to continue.
 Press **B3** to return to the Live display.
 Press **B4** to reset the readings.

	Min	- - - % LEL
Next	19.3	% O2
Live	- - -	PPM H2S
Clr	- - -	PPM CO

4. STEL readings for toxic gases.
 Press **B1** to continue.
 Press **B3** to return to the Live display.

	STEL	- - - % LEL
Next	- - -	% O2
Live	0	PPM H2S
	6	PPM CO

GS700 USER GUIDE

- LTEL readings for toxic gases.
 Press **B1** to continue.
 Press **B3** to return to the Live display.

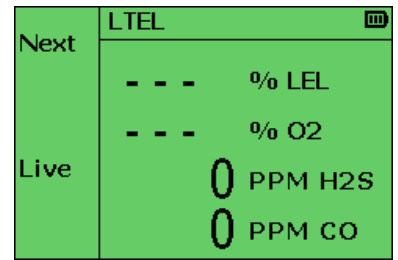

- HiHi alarm set-points.
 Press **B1** to continue.
 Press **B3** to return to the Live display.

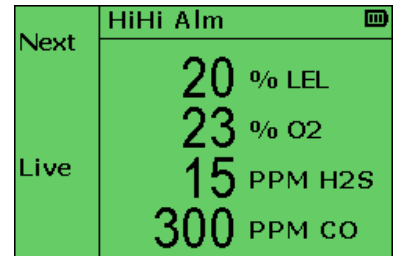

- Hi or Lo alarm set-points.
 Press **B1** to continue.
 Press **B3** to return to the Live display.

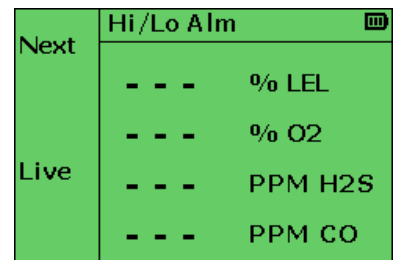

- LoLo alarm set-points.
 Press **B1** to continue.
 Press **B3** to return to the Live display.

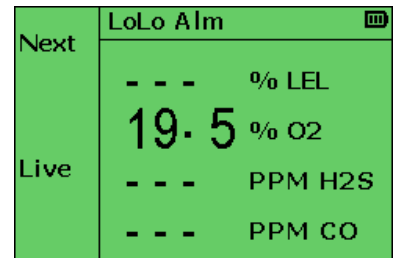

- STEL alarm set-points.
 Press **B1** to continue.
 Press **B3** to return to the Live display.

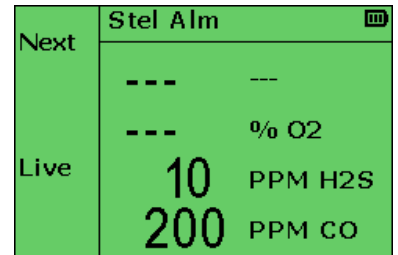

- LTEL alarm set-points.
 Press **B1** to continue.
 Press **B3** to return to the Live display.

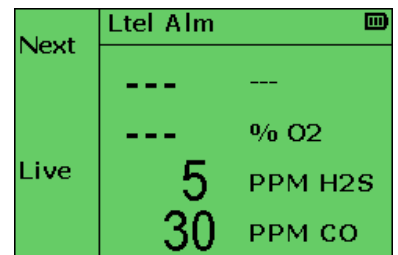

- Current readings.
 Press **B1** to continue to the maximum readings display (see step 2).
 Press **B3** to return to the Live display.

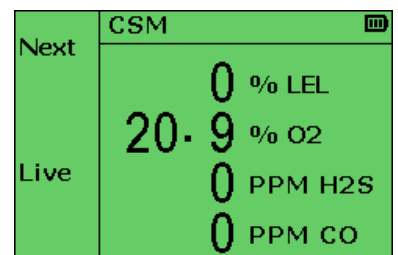

Alarms

When measured gas levels go above or below the instrument alarm set-points, the following alarms may be triggered:

- Audible - buzzer will sound (tone will differ depending on alarm type)
- Visual - 360° LED bar and top plate LED's will flash red (flash will differ depending on alarm type)
- Display - backlight turns red and alarm flags are displayed



Alarm Acknowledge

- The display will show the alarming gas level alternating with the alarm flag.
- Alarms will stay latched until acknowledged by the user.
- Press **B3** to acknowledge (Ack) the alarm. Only when the gas levels are safe.



Non-latching alarms will reset automatically when the gas levels are safe.

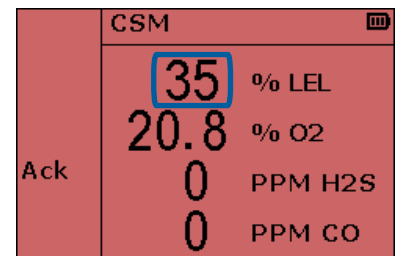

Alternates with

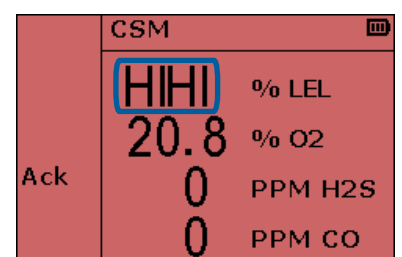

Gas Alarm Types



It is the responsibility of the user to ensure that the alarm set-points are appropriate for the safe operation and legal requirements of the country / industry in which the instrument is being used.



By default, gas alarms are set in accordance to international standards. How the instrument responds to the alarm set-points being triggered is configuration dependant.

Hi or HiHi Alarm

- Gas types with a Hi / HiHi alarm set-point.
 - » Flammable
 - » Oxygen
 - » Toxic
- The example shows a Flammable LEL alarm.

CSM	
Ack	35 % LEL
	20.8 % O2
	0 PPM H2S
	0 PPM CO

Alternates with

CSM	
Ack	HIHI % LEL
	20.8 % O2
	0 PPM H2S
	0 PPM CO

Lo or LoLo Alarm

- Oxygen is the only gas to have a Lo / LoLo alarm set-point.
- The example shows an Oxygen alarm.

CSM	
Ack	0 % LEL
	18.5 % O2
	0 PPM H2S
	0 PPM CO

Alternates with

CSM	
Ack	0 % LEL
	LOLO % O2
	0 PPM H2S
	0 PPM CO

TWA Alarms

- A Time Weighted Average (TWA) gas level, is the average gas level measured over a specific period of time.
 - » Short Term Exposure Limit (STEL) - 15 minutes
 - » Long Term Exposure Limit (LTEL) - 8 hours
- Toxic gases have STEL / LTEL alarm set-points.
- The examples below show:
 - » H₂S STEL alarm, with a gas reading of 12PPM and a STEL alarm flag.
 - » CO LTEL alarm, with a gas reading of 38PPM and a LTEL alarm flag.

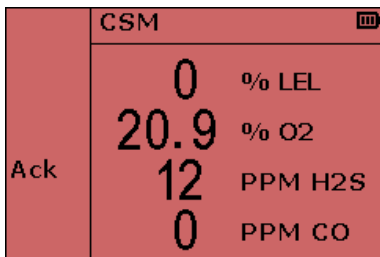

Alternates with

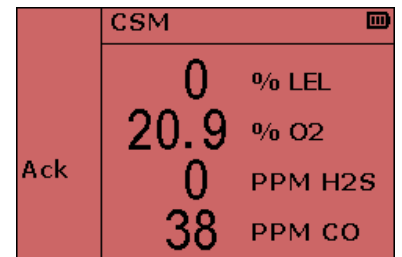
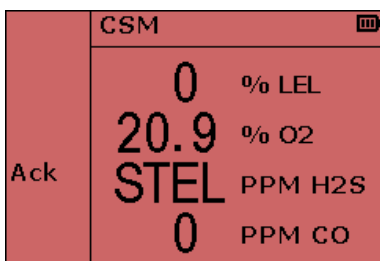

Alternates with

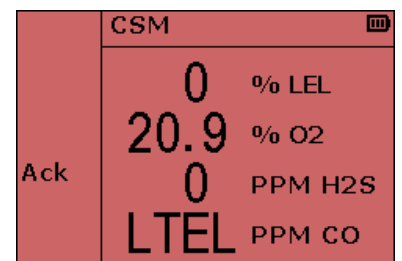

Live readings are shown (not calculated averages).

Over Range Alarm

- In the event of the flammable gas (LEL) sensor being exposed to a high concentration of flammable gas, the instrument has an over- range alarm.
- If the LEL sensor is exposed to a gas reading above 100% LEL, EEE will alternate with the HIHI alarm flag.

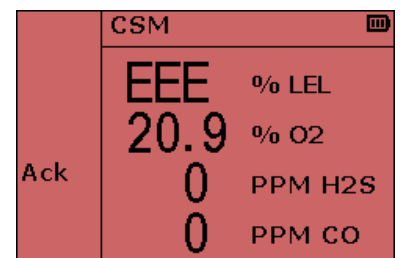

Alternates with

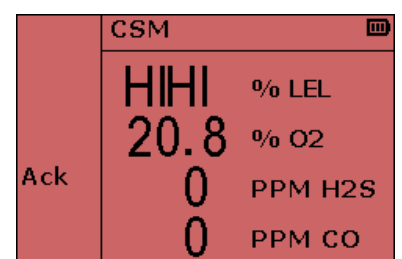



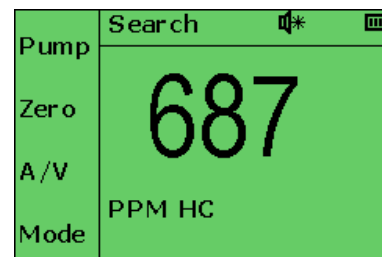

Geiger Alarm

An audible and visual Geiger alarm, enabled in the PPM Flammable range, provides indication of a larger gas concentration via an increasing rate of sounder and LED pulses.

Pressing **B3** will change the audio / visual (A/V) indicator options:



Key Press	Geiger Indicators		
	Display Icon	Audible	Visual
B3 - A / V			
Default		OFF	OFF
1 st Press		ON	OFF
2 nd Press		OFF	ON
3 rd Press		ON	ON
4 th Press - Returns to default		OFF	OFF

Alarm Mute

If configured, the audible alarm can be muted for 60 seconds. However, the visual and displayed alarms will remain active. After 60 seconds the audible alarm will reactivate.

When the audible alarm is muted and gas levels fall below the alarm set-points:

- Latching alarm - the visual / displayed alarms can be cleared (Ack) by pressing **B3**.
- Non-latching alarm - the visual / displayed alarms clear automatically.

Confidence Signal

The confidence signal is an audible (beep) and / or visual indication (360° LED bar - green LED's), every 10 seconds, that the instrument is operating correctly. The confidence signal is enabled in CSM mode only.

Fault Alarm Types

Sample Fault

A fault with the GS700 flow due to the sample path being blocked, water ingress, a blocked filter or pump failure.

- Functionality is disabled and 'Sample fault' flashes OFF and ON.
- Audible alarm, visual red LED's on top plate and red display backlight activate.
- The sample path and filters should be checked for a blockage or water ingress.
- Once the blockage is cleared, press **B1** to restart the pump.

i In CSM mode, once the blockage is cleared, the pump will automatically restart.

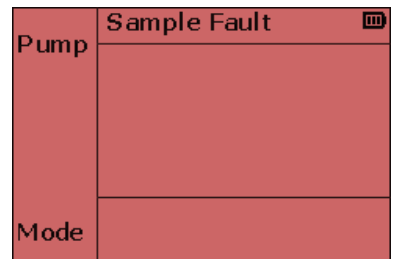

Alternates with

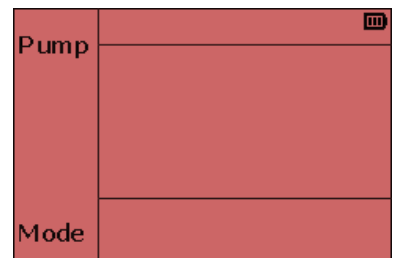

Zero Fault

Indication that the zero gas reading is outwith its calibration limits.

- Zero alarm flag and %LEL alternate on the display.
- Audible alarm , visual red 360° LED bar activate.

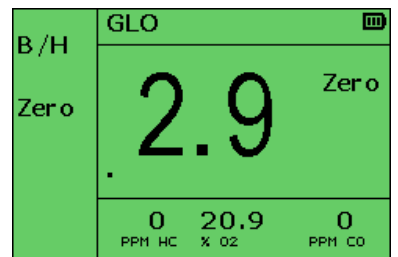

Alternates with

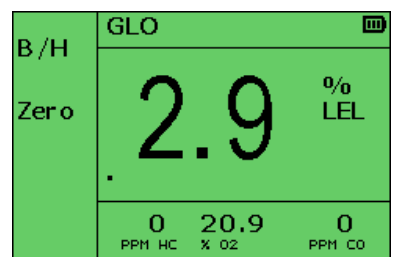

- Press **B2**, to zero.

i Always Zero in fresh air.

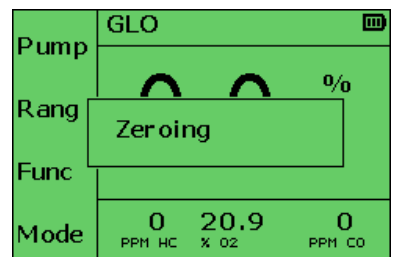

Calibration Required

If configured, during instrument warm-up a 'Cal Due' message will be displayed.

- Press **B1** to continue.
- Press **B4** to switch off.

Alternatively, the 'Cal Due' message can be configured to force the user to switch off the instrument.

- Press **B4** to switch off.

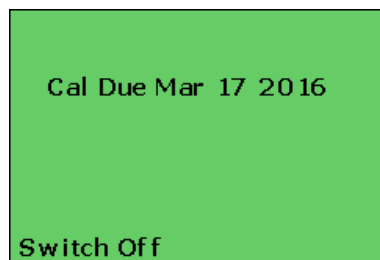
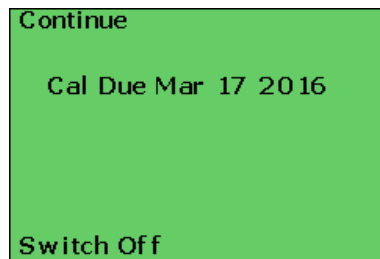

Battery / Charging

The GS700 has 2 battery options:

- Alkaline.
- Lithium-Ion rechargeable.

When the battery level becomes low:

- 'Low Bat' message will flash on the display.



Battery life is now approximately 30 mins and the batteries require to be replaced or recharged.

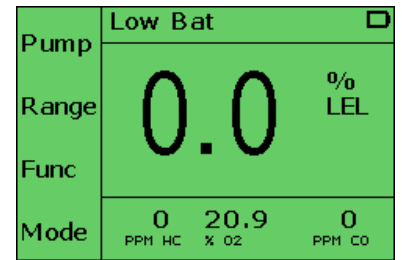

Alternates with

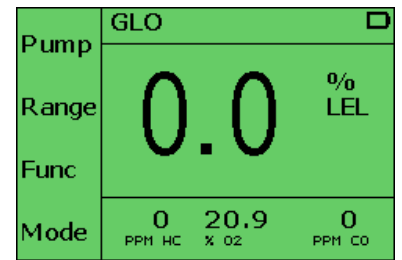

Replacing Alkaline Batteries



Only use the following approved size 'D' (LR20) alkaline batteries:

- DURACELL - MN1300 or ID1300
- ANSMANN - INDUSTRIAL or XPOWER
- PANASONIC - EVOLTA



The following procedure should be carried out in a safe area.

1. Using the 4mm hex driver (supplied), loosen the 2 instrument base screws.



2. Remove the battery cover.



3. Remove the 3 old batteries.
4. Check battery compartment for damage to spring contacts or corrosion on springs.
5. Insert the 3 new batteries observing correct polarity. Polarity markings indicated in battery compartment.



Do not mix old and new alkaline batteries. Do not use rechargeable batteries.

6. Replace battery cover and fasten the base screws.

Recharging the Battery Pack

The Lithium-Ion battery pack is recharged using the GMI charger cradle. The battery pack can be charged fitted to the instrument or separately.



Only use GMI approved batteries and chargers. Batteries must be charged in a safe area.



To fully charge the battery pack takes up to 9 hours.

Instrument Charging

1. Ensure the GS700 is switched off.
2. Ensure the charging cradle is switched on. Shown by the power LED (green).
3. Place the GS700 into the charging cradle, as illustrated.





The alignment of the GS700, is moulded on the surface of the charger cradle.



- The charging icon on the instrument will flash until fully charged.

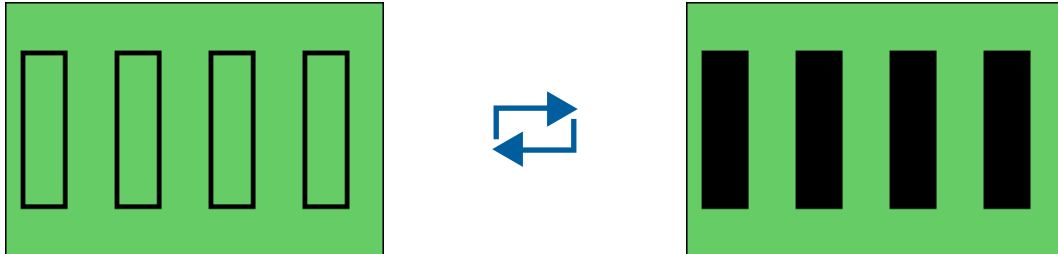

- On completion, remove from charging cradle, as illustrated.



Battery Pack Charging

- Remove the battery pack from the instrument, [see replacing the battery pack](#).
- Ensure the charging cradle is switched on. Shown by the power LED (green).
- Place the battery pack into the charging cradle, as illustrated.



- 4. The orange LED on the battery pack indicates the battery pack is charging. When the LED switches off, the battery pack is fully charged.



- 5. On completion, remove from charging cradle, as illustrated.



- 6. Fit the battery pack onto the instrument.

Maintenance

Cleaning

Display Window

- An optical cloth **MUST** be used to clean the display window, as the window is susceptible to scratches. In extreme cases a mild screen solution may be used with the optical cloth to remove stubborn stains.

Outer Casing

- The outer, impact resistant, casing of the GS700 may be cleaned using a non-abrasive damp cloth. Rub the cloth over the outer casing to remove any dirt and grime. In extreme cases, a mild soap solution may be used with a non-abrasive cloth to remove stubborn marks.



Do not use polishes containing silicon or solvent to clean the instrument as these may affect the gas sensors.



Do not use abrasive materials or strong volatile chemical solutions as these could damage the impact resistant casing.

Probe Handle Filter Replacement

Hydrophobic and cotton particulate filters in the probe handle minimise the danger of water and dust ingress.

If a blockage occurs, the message 'SAMPLE FAULT' will be displayed. Check the sample line and probe handle for a blockage. When cleared, press **B1** to continue.

Replace the filter(s) if the message does not clear.

To replace the filter(s):

1. Unscrew the probe handle assembly.
2. Remove the cotton particulate filter and discard.
3. Remove the hydrophobic filter.
4. Clean the probe handle to make sure it's free from dirt and water.
5. Fit a new cotton particulate filter.
6. Fit the new hydrophobic filter. The yellow label on the filter fits against the yellow label on the probe handle.
7. Reassemble the probe handle assembly.

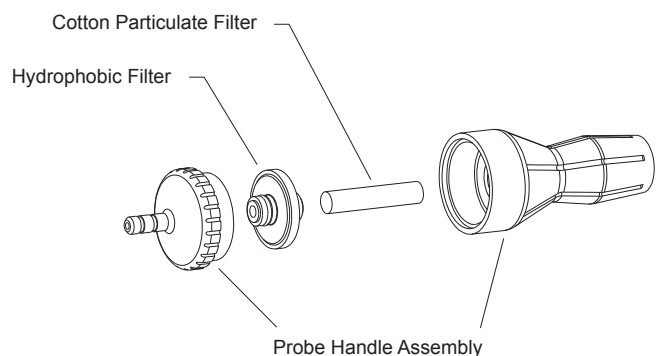

Replacing the Dust Filter

Cotton particulate (dust) filters, minimise the danger of dust ingress. Removing the inlet nozzle allows access to the dust filter.

1. Using a small coin or appropriate sized flat bladed screwdriver, remove the inlet nozzle.



2. Remove the dust filter from the inlet nozzle.

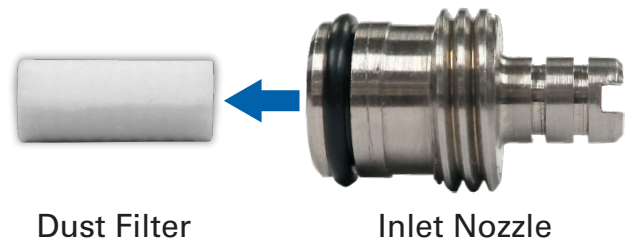

i The dust filter should be removed for inspection periodically.

3. Clean the inlet nozzle to make sure it's free from dirt and water.
4. Fit a new dust filter into the inlet nozzle.
5. Fit the inlet nozzle.

i Ensure the inlet nozzle screw thread is correctly located, before fitting.



The GS700 must never be switched on without suitable filters installed.

Bump Test (Optional)

A bump test verifies sensor response and alarm operation by exposing the GS700 to a known concentration of gas.

Different methods of bump test are available:

- Automatic bump test
- Manual bump test



When performing a bump test, the test gas concentration should be high enough to trigger the instrument's alarms.



Automatic Bump Test

The Gas Delivery Unit (GDUnet) is used to perform automatic bump tests. The GDUnet provides controlled delivery of test gas via one of the following applications:

- Instrument Management System (IMS)
- PC / *flexiCal Plus* software
- Standalone Mode



Automatic bump test equipment, consisting of both hardware and software, are manufactured by GMI. For further details contact GMI or an authorised distributor.

Manual Bump Test

Requires the user to control the delivery of gas during testing.

The following kit is required to perform a bump test:

- Calibration Test gases
- On demand regulator valve
- Sample tubing

To perform a manual bump test, follow this process:

1. Press **B4** to switch on the GS700. If enabled, 'Bump' will be displayed in the bottom right hand corner.



- After instrument warm-up the bump test menu will be displayed. Gas should now be applied to the instrument.

	Bump
	20.9 % O2
	0 PPM H2S
	0 PPM CO
	0 % LEL
Abort	Apply bump test gas

 The bump test can be aborted at any time by pressing **B4**.

- Connect the 'On Demand Flow Regulator' to the gas cylinder.
- Connect the tubing from the regulator to the instrument inlet nozzle.
- When the measured gas reading is within configured limits the audible and visual alarms will be present followed by 'PASS' displayed next to the tested gas.

	Bump
	20.9 % O2
	0 PPM H2S
	0 PPM CO
	Pass % LEL
Abort	Apply bump test gas

- Follow steps 3-5 for remaining gas ranges. When complete all gas ranges should show 'PASS'.

	Bump
	Pass % O2
	Pass PPM H2S
	Pass PPM CO
	Pass % LEL
Abort	Apply bump test gas

- Next, the display will automatically move onto a request for confirmation that audible and visual alarms were present.
Press **B1** to confirm.

Yes	Bump
No	Confirm AV alarm

- Purge the instrument of gas, back to air. The display will then return to the normal operating display.

	Bump
	18.5 % O2
	45 PPM H2S
	470 PPM CO
	58 % LEL
	Purge to air

 On completion of a manual bump test, the result is stored in the instrument.

Bump Fail

A manual bump test will fail if:

- A measured gas reading is above / below the configured limit.
- The audible and visual alarms fail to alert the user. Press **B4** to confirm a fail.

The instrument must be switched off, press **B1** for 3 seconds.

	Bump
	Pass % O2
	Pass PPM H2S
	Pass PPM CO
	Fail % LEL
Abort	Apply bump test gas

	Bump
Yes	
No	Confirm AV alarm

	Bump
	Failed - Switch off



Should an instrument fail a bump test, recalibration **MUST** be performed.

Calibration

The GS700 has been calibrated for a particular flammable gas mixture.



Where any doubt exists the instrument should be returned to GMI or an authorised distributor for calibration.

Different methods of calibration are available:

- Automatic Calibration
- Manual Calibration

Automatic Calibration

The fully automatic Gas Delivery Unit (*GDU_{net}*) provides controlled delivery of gas via one of the following applications:

- Instrument Management System (IMS)
- PC / *flexiCal Plus software*
- Standalone Mode



Manual Calibration

Requires the user to control the delivery of gas during calibration.

GMI's *flexiCal Plus software* facilitates:

- Setting up of the calibration test.
- Step by step instruction during calibration.
- Storage of test results files.



Both automatic and manual calibration methods, consisting of both hardware and software, are manufactured by GMI. For further details contact GMI or an authorised distributor.

Calibration Validity

Calibration validity is the responsibility of the user. Under normal operating conditions 12 month period can be expected. This is no guarantee, however, as the precise application of the product is unknown to GMI. Individual codes of practice may dictate shorter periods.

Regular checking establishes a pattern of reliability and enables the calibration check to be modified in line with operational experience. The higher the risk, the more frequently the calibration should be checked.

Accessories / Spares

Accessories

GMI Part No.	Part Description
49460	Charger cradle c/w universal power supply
14750X(Q)	Auto calibration package c/w GDUnet, s/w & 6 mm fittings (Q - for 1/4 in. fittings)
99118	On demand regulator valve
12712	Clear sample line (order per metre)
12393	Plastic probe - 80 cm solid end
42700	Extended survey probe assembly - c/w bellows probe
42800	Extended survey probe assembly - c/w swan neck probe
42200	Semiconductor flexi probe assembly (GS700 MUST be fitted with a semiconductor probe connection)

Common Spares

GMI Part No.	Part Description
49221	Rechargeable Battery Pack
10278	Alkaline Battery (Duracell Procell MN1300)
12451	Hex Driver
67163	Instrument Dust filter - Box of 30
12358	Probe Hydrophobic filter
10077	Probe Cotton filter - Box of 10
42197	Semiconductor flexi probe assembly filter disc



For a comprehensive list of accessories, probes, spares and calibration gases, contact your local distributor, or alternatively, GMI Ltd.

Specification

Instrument Performance

Gas	Sensor Type	Range	Resolution
ppm	Semiconductor	0 - 1000 ppm 0 - 10,000 ppm	1 ppm 1 ppm
LEL	Infrared	0 - 9.9% 10 - 100%	0.1% 1%
Volume Gas	Infrared	0 - 5% 5% - 100%	0.1% 1%
CO	Electrochemical	0 - 1000 ppm	1 ppm
O₂	Electrochemical	0 - 20.9% 21% - 25%	0.1% 1%
H₂S	Electrochemical	0 - 100 ppm	1 ppm

Instrument performance complies to the following standards:

- Flammable - BS EN / IEC 60079-29-1
- Flammable - CSA 22.2 No. 152 and ANSI/ISA-12.13.01
- Toxic - BS EN 45544
- Oxygen - BS EN 50104

GS700 will indicate if the gas sample is natural gas or Methane, providing:

- The measured sample is >30% LEL
- The sample source contains a minimum of 2% Ethane



All the values are typical at normal temperature and pressure. Humidity is between 0% and 90% (non-condensing). Pressure changes at the inlet and exhaust are minimised as they may cause transient changes in reading.

Instrument Specification

Dimensions	190 x 98 x 107 mm
Weight	1.4 kg (Alkaline), 1.3 kg (Rechargeable)
Operating Temperature	-20°C to 50°C (-4°F to 122°F)
Humidity	0 - 90% RH non-condensing
Construction	Polycarbonate ABS with TPE over-moulding
IP Rating	IP55 (Protected from dust & water jets)
Display	Monochrome LCD (240 x 160 pixels) with automatic bi-colour backlighting
Alarms	360° highly visible flashing LED Sounder ~ 90 db at 0.3 m
Sampling System	Integral pump with flow fail sensor. Sample path is protected by a hydrophobic and cotton filter. Flow rate: ~ 0.5 l/min with no restriction. Response times increase ~ 2 second per metre of tubing used. Maximum tubing length 30 metres.
Power Source	Alkaline Batteries: 3 x size 'D' (LR20), or Rechargeable Battery Pack
Approved Batteries	Alkaline: Duracell - MN1300 or ID1300 Ansmann - Industrial or XPower Panasonic - EVOLTA Rechargeable: GMI rechargeable battery pack
Battery Life	20 hours (Alkaline & Rechargeable)
Warranty	2 years (excluding consumables)

Datalogging

*500 session logs, each log can include:

- Date / time
- User ID
- Modes of operation
- Gas readings / activated alarms
- Calibration / bump test data
- Barhole logs / GPS location data

Oldest log will be overwritten when full.



* Session log: the time from instrument switch on, until instrument switch off.

Alarm Set-points



It is the responsibility of the user to ensure that the alarm set-points are appropriate for the safe operation and legal requirements of the country / industry in which the instrument is being used.

Gas	Hi	HiHi	Lo	STEL	LTEL
LEL	-	20%	-	-	-
CO	-	300 ppm	-	200 ppm	30 ppm
O2	-	23.0%	19.5%	-	-
H2S	-	15 ppm	-	10 ppm	5 ppm



The above table shows example alarm set-points. Alarm set-points are configured during instrument procurement.

Soft-Key Button Glossary

The following table shows Soft-Key options that may be displayed.

Feature	Description
Abort	Abort testing
Ack	Acknowledge alarm
A/V	Audio / visual
B/H	Barhole test
Clear	Clear present readings
Func	Shows additional functions
GPS	Show GPS coordinates
Live	Return to live gas readings
Log	Manual datalog
Mode	Available operating modes
Next	Go to next gas reading or alarm level
No	Reject selection
Pump	Toggle the instrument pump
Purge	Purge gas from sensors
Quit	Exit application
Range	Changes the visible gas range
Retry	Retry the soundness test
Start	Begin an application
View	View gas readings and alarm levels
Yes	Confirm selection
Zero	Zero sensor
+	Increase reading
-	Decrease reading
↓	Shows additional functions

Warranty

The GS700 has a standard warranty of 2 years against faulty electronic and mechanical parts, e.g. pump, sensors, PCB's, batteries (excludes consumable parts, e.g. filters).

For further details, please contact GMI Ltd (UK).



Warranty does not include damage caused by misuse, e.g. mechanical impact or water ingress and provided that any service or calibration work has been carried out by the manufacturer or authorised agent.

Liability

Piped natural gas has a range of compositions, and in some cases may be chemically similar to non-piped gases present in the atmosphere. Therefore any GMI products which include a Pipeline Gas / Non pipeline Gas test function is for indication and advisory purposes only and should not be relied upon as the sole indicator for confirming the type of gas present in the environment. GMI shall not therefore be held liable for any direct costs or consequential costs, losses or expenses incurred by the user whilst solely relying on a Pipeline Gas test function in order to determine the presence of Piped natural gas.

Customer Support

If you have any questions or need assistance, customer support is here to help.

Go to www.tycogfd.com, where you can select from a number of customer support options.

You can also contact customer support at:

Tel: +44 (0)141 302 8319

Email: customerservice@gmiuk.com

Disposal

When no longer in use, dispose of the instrument carefully and with respect for the environment. Refer to WEEE directive statement (Europe only), such as: In compliance with the WEEE directive, GMI will dispose of the instrument without charge if the instrument is returned to GMI.

Head Office

Inchinnan Business Park
Renfrew
Scotland
PA4 9RG
Tel: +44 (0)141 812 3211
Fax: +44 (0)141 812 7820
sales@gmiuk.com
www.tycogfd.com

Service & Calibration Centre

25 Cochran Close
Crownhill
Milton Keynes
MK8 0AJ
Tel: +44 (0)1908 568 867
Fax: +44 (0)1908 261 056
service@gmiuk.com

